

Whatley

Composite Poles



INNOVATIVE
SITE AND STREET
LIGHTING



A **valmont**  COMPANY

INDEX

Composite overview	5
Installation systems	6
XTREME™ base covers	7
RS4 straight round poles	8
Round tapered poles	10
Options & Accessories	14
Mast arms	15
Direct embedded details	16
Specifications	16
Anchor Base details	17

Composite technology for demanding applications and the harshest environments

Whatley lighting standards incorporate the same composite technology used in the aerospace, automotive and building industries because of its design flexibility and high strength-to-weight ratio.

Composite materials provide long lasting durability and value under the toughest environmental conditions.

These precision engineered lamp posts stand up to extreme temperatures, hurricane-force winds and harsh coastal climates. They will not rust, rot or corrode, even when exposed to moisture, salts, fertilizers or chemicals. Plus, they're non-conductive, as well as impact, vibration and graffiti resistant.

- No rust or corrosion
- Safe–non conductive
- High wind shear resistance
- Lower installed cost than metal or concrete poles

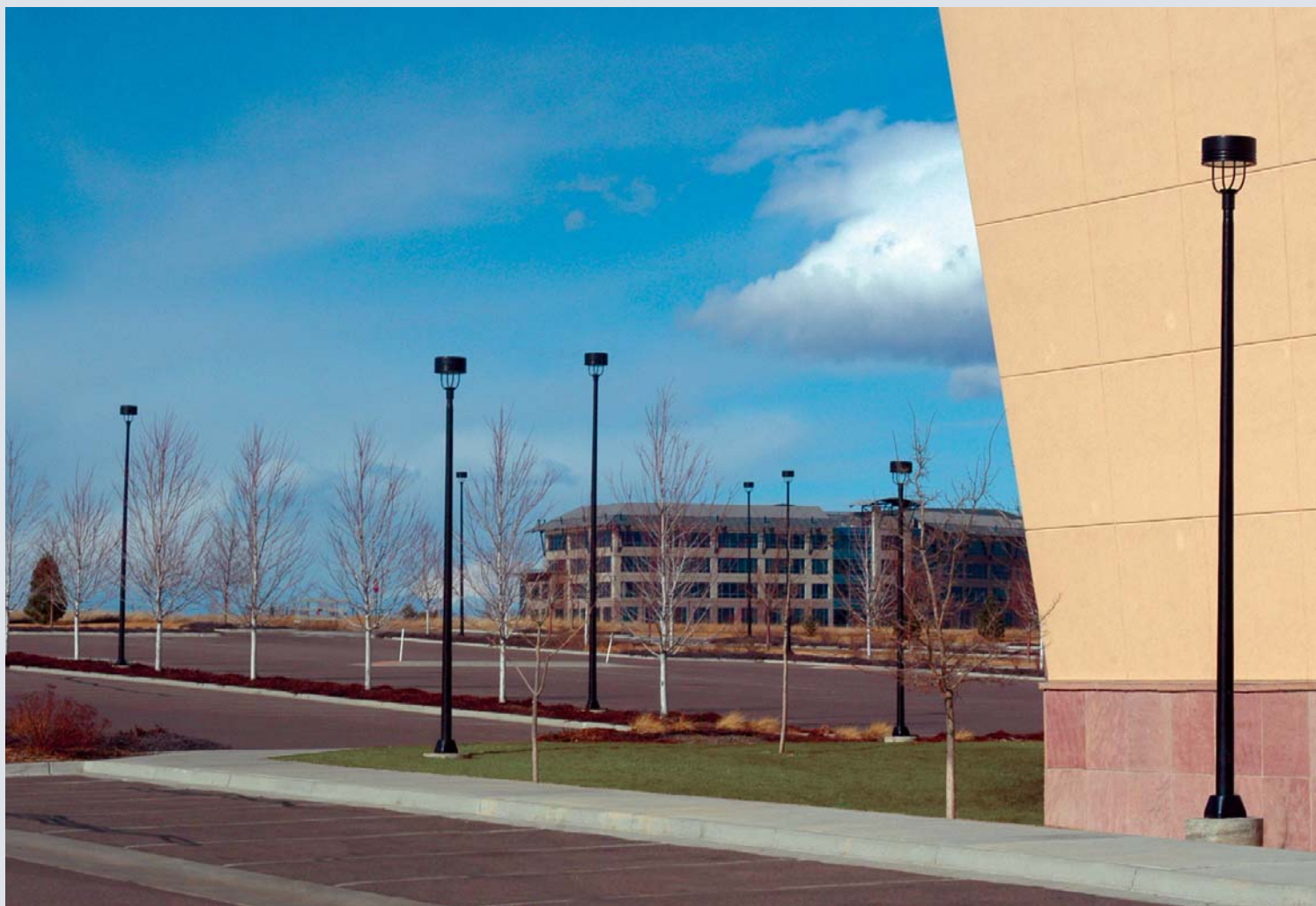

A complete range of standard lighting poles, and decorative lamp posts



Standard composite pole



Decorative pole with an XTREME base

Composite technology produces the strongest poles for the severest site conditions

Whatley poles have the highest tensile, flexural and compressive strength of any pole material.

The core of Whatley's extraordinary strength is continuous wound fiberglass, one of the strongest materials on earth. Computer controlled machines spiral wrap the continuous filament strands around revolving mandrels. Over 10,000 miles of continuous fiberglass filaments are used in every pole. The filament strands are saturated with a pigmented resin before being wound for consistent strength and quality.



Whatley composite poles are engineered with a minimum of a 2:1 safety factor for the specified wind loads. These composite lighting poles have exceeded severe wind loading conditions.

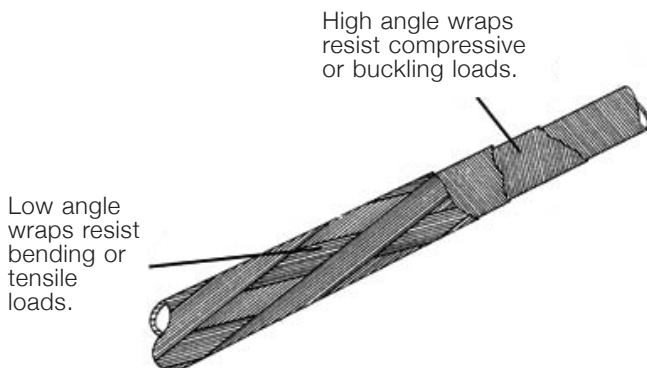

Whatley composite poles have been proven to be stronger than any fiberglass pole of the same weight. A state department of transportation, with one of the most stringent testing procedures, found a Whatley lighting pole to be twice as strong as a competitor's fiberglass pole. Whatley poles exceed the AASHTO and ANSI C136.20 national specifications for deflection and stiffness.

Installation systems

Direct Embedded

Just like the millions of utility and telephone poles installed throughout the country, Whatley composite poles can be directly embedded—“planted” in the ground, saving time and resources. There is no concern about corrosive soils destroying the integrity of the embedded pole when you specify a Whatley pole.

- Less than half the cost of a concrete anchor base
- No rigging equipment required
- Less labor and materials to install

DIRECT EMBEDDED

Direct embedded poles can be installed for half the cost of an anchor base pole with a concrete foundation.

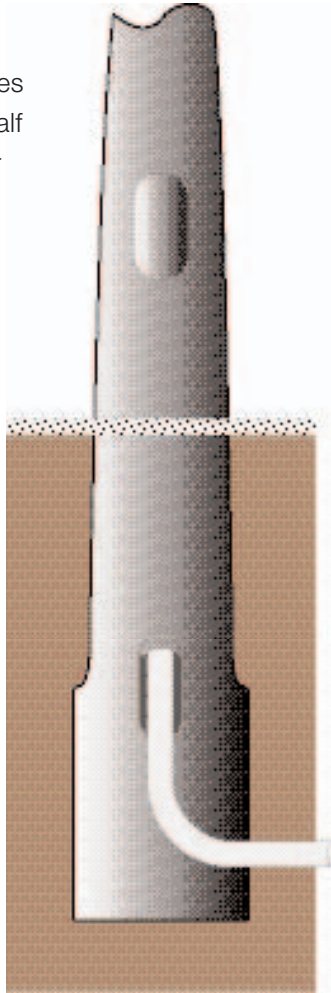

Anchor Base

All Whatley poles can be specified with an anchor base for new installations, or for replacement of existing poles with concrete footings. Composite poles are less costly to install than metal poles because of their comparatively low weight. Base plate assemblies are galvanized steel for corrosion resistance.

- Good for retrofit applications

ANCHOR BASE

All Whatley poles can be ordered with a traditional anchor base for new or retrofit applications. The base assembly is galvanized steel for corrosion resistance.

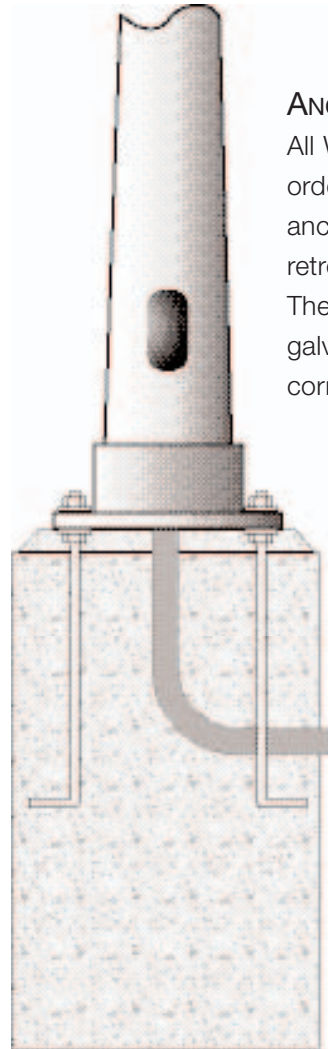

A lasting finish

Corrosion free materials and a tough top coating minimizes maintenance

All Whatley products are finished with a UV-resistant urethane coating, providing an extremely durable finish that retains its gloss even after a 5000 hour accelerated weathering test (ASTM G154) to the sun, with no dulling or chalking of the surface. This process exceeds the industry standard by a factor of two, for maximum color retention on outdoor fixtures and poles.

And unlike concrete poles, the Whatley finish is exceptionally resistant to graffiti, which is easily removed from the surface.



Base Covers

All Whatley base covers are made of our patented XTREME elastomeric urethane composite material that is unbreakable and corrosion free. See the Whatley Decorative Pole brochure for a full line of decorative base covers in three sizes for all types of applications.



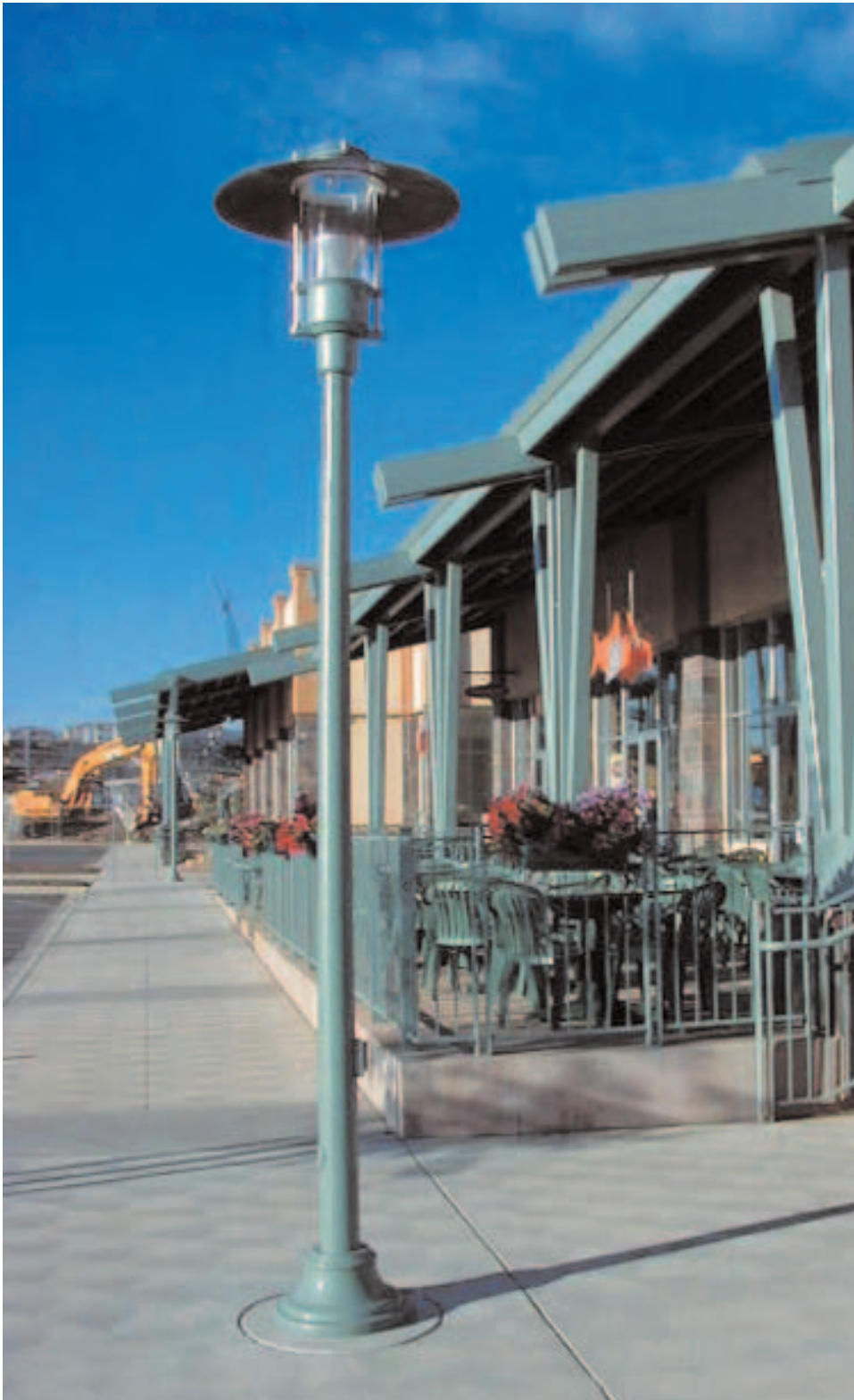

- 6'/1.8M TO 16'/4.9M mounting heights
- Direct embedded option for lower installation cost
- Anchor base with one piece base cover
- Decorative XTREME™ base covers available

Ordering Information

SAMPLE CATALOG NUMBER LOGIC

	B	C	D	E	F	G
RS4	14	DE	DGR	•	•	DTC
RS4	12	AB	MAT	30	-40	•
POLE	ABOVE GRADE HEIGHT	INSTALLATION METHOD	COLOR	TENON O.D.	TENON HEIGHT	OPTIONS

B POLE HEIGHT - ABOVE GRADE

Cat No.	Description	WT-(AB)	Wind Loading Data						
			WIND SPEED (MPH) WITH 3 SECOND GUST FACTOR						
			90	100	110	120	130	140	150
6	6 feet/1.83M	38	20.0	16.0	13.1	10.9	9.3	8.0	6.9
7	7 feet/2.13M	42	17.2	13.8	11.2	9.3	7.9	6.8	5.8
8	8 feet/2.44M	45	15.1	12.0	9.7	8.0	6.8	5.8	5.0
9	9 feet/2.74M	48	13.3	10.5	8.5	6.9	5.8	5.0	4.3
10	10 feet/3.05M	50	11.8	9.3	7.4	6.0	5.1	4.3	3.7
11	11 feet/3.35M	53	10.5	8.2	6.5	5.3	4.4	3.7	3.2
12	12 feet/3.66M	56	9.4	7.3	5.7	4.6	3.8	3.2	2.7
13	13 feet/3.96M	60	8.5	6.5	5.0	4.0	3.3	2.8	2.3
14	14 feet/4.27M	63	7.6	5.8	4.4	3.4	2.8	2.3	2.0
15	15 feet/4.57M	66	6.8	5.1	3.8	2.9	2.4	2.0	1.6
16	16 feet/4.88M	68	5.7	4.2	3.1	2.3	1.8	1.5	1.2

- Weights listed are with anchor bases. Deduct twenty (20) pounds for direct embedded poles.

Wind speed values are for a 3 second gust per ASCE 7-98 and AASHTO 2001. Calculated per ASCE 7-98, 50-year recurrence interval, 1.0 Importance factor. Assumes load 12 inches above the pole top. Safety factor = 2.0

G OPTIONS FOR RS4 POLES

Cat No.	Description
DTC	Top pole cap and drilling for a side mounted arm(s). Provide a template or drawing for the mounting hole locations and wireway.
FLD	Top pole cap. Field drill pole to accept luminaire.
R1	Single receptacle and housing with spring loaded cover. Painted to match the pole. Standard location is 12"/305mm below the top of the pole.
RC	Receptacle housing and a NEC approved cover. GFCI receptacle by others. Standard location is 12"/305mm below the top of the pole.
RBC	XTREME™ elastomeric urethane composite base cover for direct embedded DE installations. Standard with anchor base – AB configuration. Painted to match the pole color.

C INSTALLATION METHOD

Cat No.	Description
DE	Direct Embedded
	Below grade depth
	6 to 9 feet 2ft/.62M
	9 to 14 feet 3ft/.91M
	15 to 16 feet 4ft/1.2M

Embedment depth may vary with local soil and wind conditions.

AB Anchor Base

D COLORS REFER TO PAGE 10

E TENON O.D. (OUTSIDE DIAMETER)

Cat No.	Description
23	2 3/8" (60 mm)
27	2 7/8" (73mm)
30	3" (76 mm)
35	3 1/2" (89mm)
40	4" (102 mm)

F TENON HEIGHT

Cat No.	Description
-30	3.0" (76 mm)
-35	3 1/2" (89mm)
-40	4.0" (102 mm)
-50	5.0" (127 mm)
-60	6.0" (178mm)







• For other tenon sizes contact the factory.

ROUND TAPERED POLES

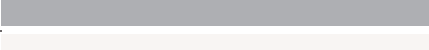

Diameter at Base = _____
 pole top diameter +
 (above ground height x .14"/ft.)
 example: 3.4" + (20 x .14) =
 3.4 + 2.8 = 6.2"

D COLORS FOR ALL ROUND TAPERED POLES

Cat No.	Description	
BLK	Black	
MTB	Matte Black	
DBZ	Dark Bronze	
DGR	Dark Green	
HTG	Hunter Green	
SLV	Silver	
WHT	White	
GRY	Grey	
CC	Custom color - Please provide a minimum 3" x 3" color chip.	
RAL	Please provide a four digit RAL color number.	

E SURFACE FINISHES FOR ALL ROUND TAPERED POLES

Cat No.	Description	
TXT	Natural texture of the reinforcing strands	

Cat No.	Description	
SMS	Smooth surface finish	

H OPTIONS FOR ALL ROUND TAPERED POLES

Cat No.	Description
DTC	Top pole cap and drilling for a side mounted arm(s). Provide a template or drawing for the mounting hole locations and wireway.
FLD	Top pole cap. Field drill pole to accept luminaire.
R1	Single receptacle and housing with spring loaded cover. Molded in dark grey color. Standard location is 12"/305mm below the top of the pole.
RC	Receptacle housing and a NEC approved cover. GFCI receptacle by others. Standard location is 12"/305mm below the top of the pole.
RBC	XTREME™ urethane composite base cover for direct embedded (DE) installations. Standard with anchor base-AB configuration. Painted to match the pole color.

11

- Pole top diameter is 3.4"/86mm, .14 inch per foot taper
- Direct embedded option for lower installation cost
- Anchor base with one piece base cover
- Decorative XTREME™ base covers available

Ordering Information

SAMPLE CATALOG NUMBER LOGIC

	B	C	D	E	F	G	H
RT34	16	DE	DGR	SMS	27	-30	
RT34	20	AB	BLK	TXT	40	-35	RC
POLE	ABOVE GRADE HEIGHT	INSTALLATION METHOD	COLOR	SURFACE FINISH	TENON O.D.	TENON HEIGHT	OPTIONS

B POLE HEIGHT - ABOVE GRADE

Cat No.	Description	WT	Wind Loading Data							
			WIND SPEED (MPH) WITH 3 SECOND GUST FACTOR							
			90	100	110	120	130	140	150	
10	10 feet/3.10M	29	7.4	5.7	4.5	3.6	3.0	2.5	2.2	
11	11 feet/3.35M	31	7.4	5.7	4.4	3.6	3.0	2.5	2.1	
12	12 feet/3.66M	32	7.4	5.5	4.2	3.4	2.8	2.4	2.1	
13	13 feet/3.96M	34	7.3	5.4	4.1	3.3	2.8	2.3	2.0	
14	14 feet/4.27M	39	7.2	5.4	4.1	3.3	2.8	2.3	1.9	
15	15 feet/4.57M	43	7.0	5.2	4.0	3.3	2.7	2.2	1.9	
16	16 feet/4.88M	46	6.4	4.7	3.6	2.9	2.4	2.0	1.6	
17	17 feet/5.18M	48	6.2	4.5	3.5	2.8	2.3	1.9	1.6	
18	18 feet/5.49M	51	6.1	4.4	3.4	2.7	2.2	1.8	1.5	
19	19 feet/5.79M	55	5.9	4.2	3.3	2.6	2.1	1.7	1.4	
20	20 feet/6.10M	58	5.7	4.1	3.2	2.5	2.0	1.6	1.3	
21	21 feet/6.40M	61	5.5	3.9	3.1	2.4	1.9	1.5	1.2	
22	22 feet/6.71M	65	5.3	3.8	2.9	2.3	1.8	1.4	1.2	
23	23 feet/7.01M	69	5.1	3.7	2.8	2.2	1.7	1.4	1.1	
24	24 feet/7.32M	73	4.6	3.3	2.5	1.9	1.5	1.2		
25	25 feet/7.62M	76	4.4	3.2	2.4	1.9	1.4	1.1		
26	26 feet/7.92M	80	4.1	3.1	2.3	1.7	1.3	1.0		
27	27 feet/8.32M	90	4.0	2.9	2.2	1.6	1.2			
28	28 feet/8.53M	93	3.8	2.8	2.0	1.5	1.1			
29	29 feet/8.84M	96	3.7	2.6	1.9	1.4	1.0			
30	25 feet/9.14M	100	3.7	2.5	1.8	1.3				

• Weights listed are with anchor bases. Deduct twenty (20) pounds for direct embedded poles.

Wind speed values are for a 3 second gust per ASCE 7-98 and AASHTO 2001. Calculated per ASCE 7-98, 50-year recurrence interval, 1.0 Importance factor. Assumes load 12 inches above the pole top. Safety factor = 2.0

C INSTALLATION METHOD

Cat No.	Description
DE	Direct Embedded
	Below
	Pole height grade depth
	10 to 13 feet 3ft/.91M
	14 to 24 feet 4ft/1.2M
	25 to 30 feet 5ft/1.5M

Embedment depth may vary with local soil and wind conditions.

AB Anchor Base

D COLORS REFER TO PAGE 10

E SURFACE FINISH - PAGE 10

F TENON O.D. (OUTSIDE DIAMETER)

Cat No.	Description
23	2 3/8" (60mm)
27	2 7/8" (73mm)
30	3" (76mm)
35	3 1/2" (89mm)
40	4" (102mm)

G TENON HEIGHT

Cat No.	Description
-30	3.0" (76mm)
-35	3.5" (89mm)
-40	4.0" (102mm)
-50	5.0" (127mm)
-60	6.0" (178mm)

• For other tenon sizes contact the factory.

- Pole top diameter is 4.5"/114mm, .14 inch per foot taper
- Direct embedded option for lower installation cost
- Anchor base with one piece base cover
- Decorative XTREME™ base covers available

Ordering Information

SAMPLE CATALOG NUMBER LOGIC

	B	C	D	E	F	G	H
RT45	20	DE	DBZ	TXT	40	-60	DTC
RT45	30	AB	MAT	SMT	30	-40	
POLE	ABOVE GRADE HEIGHT	INSTALLATION METHOD	COLOR	SURFACE FINISH	TENON O.D.	TENON HEIGHT	OPTIONS

B POLE HEIGHT - ABOVE GRADE

Wind Loading Data

WIND SPEED (MPH) WITH 3 SECOND GUST FACTOR

Cat No.	Description	WT	Wind Speed (MPH) with 3 Second Gust Factor						
			90	100	110	120	130	140	150
16	16 feet/4.88M	61	6.4	4.7	3.6	2.9	2.4	2.0	1.6
17	17 feet/5.18M	64	6.2	4.5	3.5	2.8	2.3	1.9	1.6
18	18 feet/5.49M	67	6.1	4.4	3.4	2.7	2.2	1.8	1.5
19	19 feet/5.79M	70	5.9	4.2	3.3	2.6	2.1	1.7	1.4
20	20 feet/6.10M	72	8.6	6.7	5.4	4.4	3.6	3.0	2.5
21	21 feet/6.40M	75	8.5	6.6	5.3	4.3	3.5	2.9	2.5
22	22 feet/6.71M	76	8.3	6.5	5.2	4.2	3.4	2.9	2.4
23	23 feet/7.01M	78	8.2	6.4	5.1	4.1	3.4	2.8	2.3
24	24 feet/7.32M	79	7.6	5.9	4.7	3.8	3.1	2.5	2.1
25	25 feet/7.62M	92	7.5	5.8	4.6	3.7	3.0	2.5	2.0
26	26 feet/7.92M	100	7.3	5.7	4.5	3.6	2.9	2.4	1.9
27	27 feet/8.32M	103	7.2	5.5	4.3	3.5	2.8	2.3	1.8
28	28 feet/8.53M	107	7.0	5.4	4.2	3.4	2.7	2.2	1.7
29	29 feet/8.84M	110	6.9	5.3	4.1	3.3	2.6	2.1	1.5
30	30 feet/9.14M	112	6.7	5.1	4.0	3.2	2.5	2.1	1.4

- Weights listed are with anchor bases. Deduct twenty (20) pounds for direct embedded poles.

Wind speed values are for a 3 second gust per ASCE 7-98 and AASHTO 2001. Calculated per ASCE 7-98, 50-year recurrence interval, 1.0 Importance factor. Assumes load 12 inches above the pole top. Safety factor = 2.0

C INSTALLATION METHOD

Cat No. Description

DE	Direct Embedded
	Below grade depth
	16 to 24 feet 4ft / 1.2M
	25 to 30 feet 5ft / 1.5M

Embedment depth may vary with local soil and wind conditions.

AB Anchor Base

D COLORS REFER TO PAGE 10

D SURFACE FINISH - PAGE 10

E TENON O.D. (OUTSIDE DIAMETER)

F	Cat No.	Description
	23	2 3/8" (60 mm)
	27	2 7/8" (73mm)
	30	3" (76 mm)
	35	3 1/2" (89 mm)
	40	4" (102 mm)

G TENON HEIGHT

G	Cat No.	Description
	-30	3.0" (76 mm)
	-35	3.5" (89mm)
	-40	4.0" (102 mm)
	-50	5.0" (127 mm)
	-60	6.0" (178mm)

- For other tenon sizes contact the factory.

- Pole top diameter is 5.0"/125mm, .14 inch per foot taper
- Direct embedded option for lower installation cost
- Anchor base with one piece base cover
- Decorative XTREME™ base covers available

Ordering Information

SAMPLE CATALOG NUMBER LOGIC

	B	C	D	E	F	G	H
RT50	36	DE	MTB	TXT	40	-50	
RT50	25	AB	HTG	SMT	35	-40	DTC
POLE	ABOVE GRADE HEIGHT	INSTALLATION METHOD	COLOR	SURFACE FINISH	TENON O.D.	TENON HEIGHT	OPTIONS

B POLE HEIGHT - ABOVE GRADE

Cat No.	Description	WT	Wind Loading Data						
			WIND SPEED (MPH) WITH 3 SECOND GUST FACTOR						
			90	100	110	120	130	140	150
20	20 feet/6.10M	88	17.1	13.7	11.1	9.2	7.8	6.6	5.7
21	21 feet/6.40M	93	17.0	13.6	11.1	9.2	7.7	6.6	5.7
22	22 feet/6.71M	103	17.0	13.6	11.0	9.2	7.7	6.5	5.6
23	23 feet/7.01M	108	16.9	13.5	11.0	9.1	7.6	6.5	5.5
24	24 feet/7.32M	112	16.8	13.4	10.9	9.0	7.6	6.4	5.4
25	25 feet/7.62M	118	16.8	13.3	10.8	9.0	7.5	6.4	5.4
26	26 feet/7.92M	123	16.7	13.3	10.8	8.9	7.4	6.3	5.3
27	27 feet/8.32M	127	16.6	13.2	10.7	8.8	7.4	6.3	5.2
28	28 feet/8.53M	132	15.5	12.3	10.0	8.2	6.9	5.8	4.7
29	29 feet/8.84M	136	15.4	12.2	9.9	8.1	6.8	5.7	4.7
30	30 feet/9.14M	141	15.4	12.2	9.9	8.1	6.8	5.7	4.7
31	31 feet/9.49M	147	15.3	12.1	9.8	8.0	6.7	5.6	4.5
32	32 feet/9.75M	155	15.1	12.0	9.7	8.0	6.6	5.5	4.4
33	33 feet/10.1M	160	15.0	11.9	9.6	7.9	6.5	5.4	4.3
34	34 feet/10.4M	165	14.9	11.8	9.5	7.8	6.5	5.2	4.2
35	35 feet/10.7M	167	14.8	11.7	9.4	7.7	6.4	5.1	4.1
36	36 feet/11.0M	172	14.6	11.5	9.3	7.6	6.3	5.0	3.9
37	37 feet/11.3M	174	13.8	10.9	8.7	7.1	5.9	4.6	3.6
38	38 feet/11.6M	180	13.7	10.8	8.6	7.0	5.7	4.5	3.5
39	39 feet/11.9M	207	13.6	10.6	8.5	6.9	5.6	4.3	3.3

- Weights listed are with anchor bases. Deduct twenty (20) pounds for direct embedded poles.

Wind speed values are for a 3 second gust per ASCE 7-98 and AASHTO 2001. Calculated per ASCE 7-98, 50-year recurrence interval, 1.0 Importance factor. Assumes load 12 inches above the pole top. Safety factor = 2.0

C INSTALLATION METHOD

Cat No.	Description
DE	Direct Embedded
	Pole height
	Below grade depth
	20 to 24 feet 4ft/1.2M
	25 to 35 feet 5ft/1.5M
	36 to 39 feet 6ft/1.8M

Embedment depth may vary with local soil and wind conditions.

AB Anchor Base

D COLORS REFER TO PAGE 10

E SURFACE FINISH - PAGE 10

F TENON O.D. (OUTSIDE DIA.)

Cat No.	Description
23	2 3/8" (60 mm)
27	2 7/8" (73mm)
30	3" (76 mm)
35	3 1/2" (89 mm)
40	4" (102 mm)

G TENON HEIGHT

Cat No.	Description
-30	3.0" (76 mm)
-35	3.5" (89mm)
-40	4.0" (102 mm)
-50	5.0" (127 mm)
-60	6.0" (178mm)

- For other tenon sizes contact the factory.

Options + Accessories

Banner Arms - Fixed



Cat No.	Description
BA-12	Single 12in/305mm arm
BA-18	Single 18in/457mm arm.
BA-24	Single 24in/610mm arm.

- Arm 1in/25mm dia. painted to match the pole. Includes two (2) unpainted stainless steel mounting bands.

Banner Arms - 3 Point



Cat No.	Description
BA3-12	Single 12in/305mm arm
BA3-18	Single 18in/457mm arm.
BA3-24	Single 24in/610mm arm.

- Arm 1in/25mm dia. and ring base painted to match the pole. Includes four (4) unpainted stainless steel mounting bands.

Flag Holder

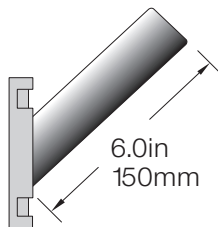

Cat No.	Description
FPH	Flag holder accepts up to a 1.625in/41mm diameter flag pole, painted to match pole. Includes two (2) unpainted stainless steel mounting bands.

Banner Arms - Spring loaded arm

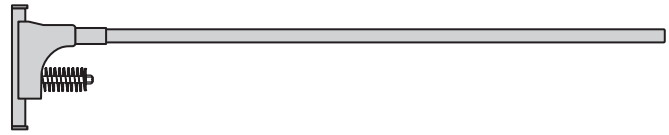

Cat No.	Description
BAS-12	Single 12in/305mm arm
BAS-18	Single 18in/457mm arm.
BAS-24	Single 24in/610mm arm.
BAS-32	Single 32in/813mm arm.

- Fiberglass arm—white (.75in/18mm dia.). Base painted to match the pole. Three (3) unpainted stainless steel mounting bands included.

Pole Mounted Receptacles

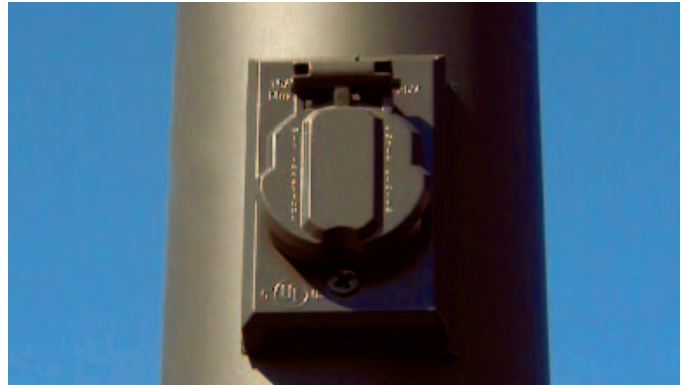

Cat No.	Description
R1	Single receptacle with housing and spring loaded cover. Molded-in dark grey color. Standard location is 12"/305mm from the top of the pole.



Cat No.	Description
RC	Receptacle housing and NEC approved cover. Standard location is 12"/305mm from the top of the pole. GFCI receptacle by others.

Mast Arms

Mast Arms

Cat No.	Description	Span	Rise	Weight	EPA
MA-48	48" mast arm	45"/1143mm	15"/380mm	6 lbs.	1.1
MA-72	72" mast arm	68"/1727mm	24"/610mm	10 lbs.	1.8
MA-96	96" mast arm	90"/2286mm	32"/812mm	15 lbs.	2.3

- Arms have a standard 2 inch NPS (2.375") slip fitter. The slip fitter has a straight end 10"/245mm long to accept the luminaire. Standard finish is satin aluminum. Painted to match pole when ordered together.

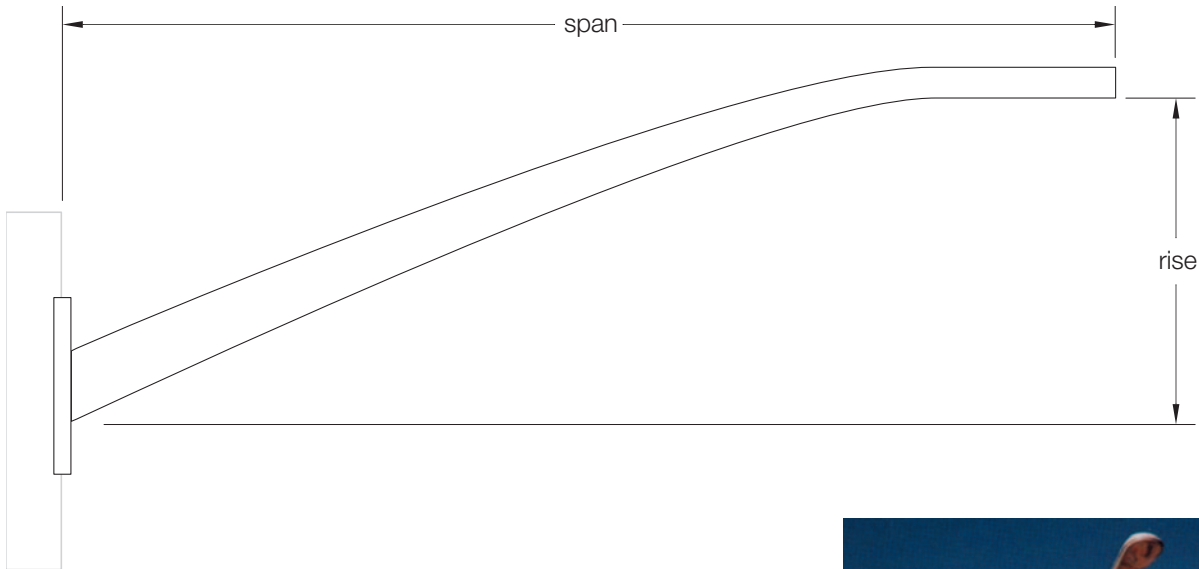

Installation Details

Direct Embedded Poles

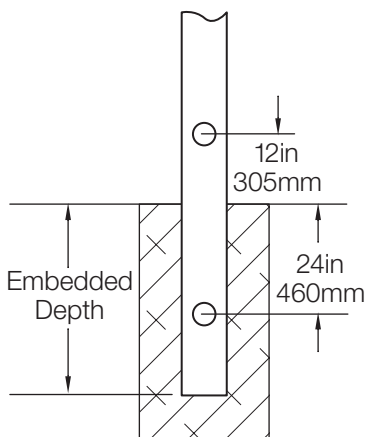

RS4 poles
hand hole:
2.0"/50mm round
conduit entry:
2.0"/50mm round

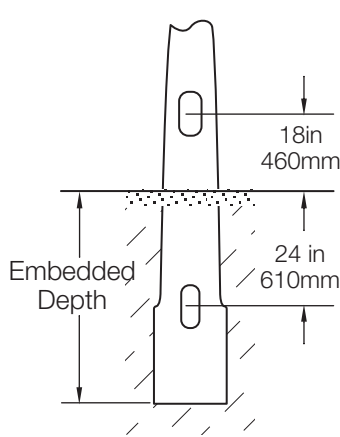

Tapered poles
hand hole and conduit entry:
2.5"/62mm x 5"/125mm

Suggested Burial Depth for Embedded Poles

Height above grade	Burial Depth
8'/2.4M TO 14'/4.3M	3'/1M
14'/4.3M TO 24'/7.3M	4'/1.2M
25'/7.6M TO 35'/10.7M	5'/1.5M
36'/7.9M TO 39'/11.8M	6'/1.8M

* Embedded depths may vary per local codes, site soil conditions, drainage and very high wind conditions.

Specifications

- Refer to individual pole spec sheets for wind loading data and recommended burial depth.

POLE SHAFT—RS4

The shaft shall be round, smooth, 4"/102mm outside diameter with a minimum wall thickness of .28"/7mm. Hand hole shall be 2"/50mm in diameter with a cover. The conduit entrance hole for direct embedded poles shall be 2"/50mm in diameter. The post shall be non-conductive and chemically inert. Anchor base shall be galvanized steel, bonded to the shaft. Post top tenon shall be galvanized steel, bonded to the pole and painted to match.

POLE SHAFT—RT35, RT45 and RT50

The pole shaft shall be round tapered, smooth with a .14"/3.5mm per foot taper. The hand hole shall be 2.5"/62mm x 5"/125mm with a cover. The shaft shall be constructed of continuous fiberglass filament combined with a thermosetting polyester resin. The glass filament shall be helically wound at alternating high and low angle layers for maximum compressive and bending strength. The hand hole area and hardware attachment areas shall be reinforced. The poles shall be designed with a minimum safety factor of 2:1 and have a maximum deflection of 10% under full wind loading conditions.

The butt end of the embedded-type post shall be enlarged to increase the resistance to rotation and provide maximum ground bearing resistance (anti-lift). The post shall be non-conductive and chemically inert.

Anchor bases shall be galvanized steel, bonded to the shaft. Post top tenon shall be galvanized steel, bonded to the pole and painted to match.

FINISH

The surface of the post shall be uniform and consistent for the entire length of the post. The polyester resins shall contain pigment to improve ultraviolet resistance. Solid coloration shall be throughout the outer shell.

The UV-resistant catalyzed urethane coating shall be extremely durable and retains its gloss after a 5000 hour accelerated weathering test to the sun (ASTM-G154), with no loss of color or chalking of the surface.

BASE COVER

The base cover shall be one piece and constructed from a proprietary elastomeric urethane and painted to match the post. The base covers shall slip over the pole.

WARRANTY

The products shall be warranted to be free of defects for three years from the date of shipment from the factory.

Anchor Base Details

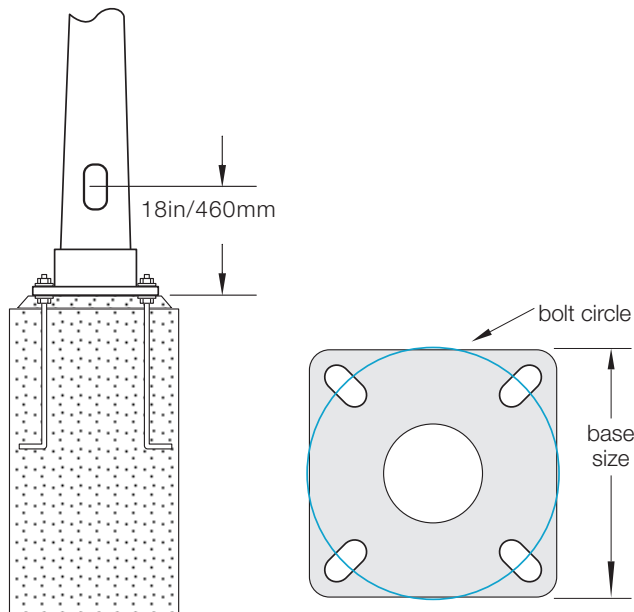

Anchor Base Dimensions for RT34

- Hand hole is 2.5"/62mm x 5"/125mm
- Anchor bolts are .75" x 21" x 3"
- Mounting slots are 1.0"/25mm x 1.5"/38mm
- Conduit entry hole in base plate is 4.0"/100mm

POLE HEIGHT	BOLT CIRCLE	BASE SIZE	BASE COVER
10'-14'	8"/203MM	8"/203MM	9" x 6"
15'-26'	10.5"/267MM	10.25"/260MM	11" x 7"
27'-30'	12"/305MM	11.5"/292MM	13" x 8"

Anchor Base Dimensions for RT45

- Hand hole is 2.5"/62mm x 5"/125mm
- Anchor bolts are .75" x 21" x 3"
- Mounting slots are 1.0"/25mm x 1.5"/38mm
- Conduit entry hole in base plate is 4.0"/100mm

POLE HEIGHT	BOLT CIRCLE	BASE SIZE	BASE COVER
15'-23'	10.5"/267MM	10.25"/260MM	11" x 7"
24'-30'	12"/305MM	11.5"/292MM	13" x 8"

Anchor Base Dimensions for RT50

- Hand hole is 2.5"/62mm x 5"/125mm
- Anchor bolts are .75" x 21" x 3" for pole up to 24 feet, taller poles 25 to 39 feet are 1" x 36" x 3"
- Mounting slots are 1.0"/25mm x 1.5"/38mm
- Conduit entry hole in base plate is 4.0"/100mm

POLE HEIGHT	BOLT CIRCLE	BASE SIZE	BASE COVER
18'-24'	12"/305MM	11.5"/292MM	13" x 8"
25'-35'	14"/356MM	13.5"/343MM	15" x 12"
36'-39'	16"/406MM	15"/381MM	16" x 12"

RS4 Anchor Base

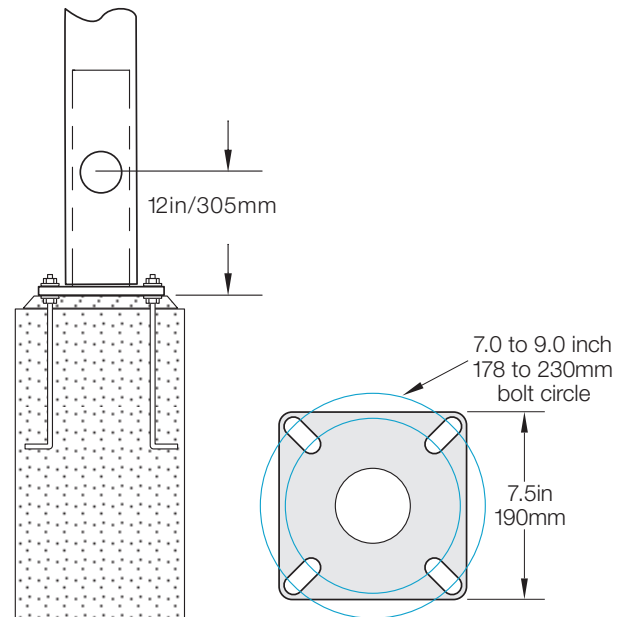

Anchor Base - for RS4 poles

- Hand hole is 2.0"/50mm round
- Anchor bolts are .625" x 21" x 3"
- Mounting slots are .75"/19mm x 1.75"/44mm
- Conduit entry hole in base plate is 2.5"/64mm
- Base cover is 9"/230mm square by 6"/150mm high

Standard Base Covers

- Indestructible XTREME™ elastomeric composite will never rust or rot. Sized to fit over each size of anchor base. One piece, painted to match the pole.
- RBC option for direct embedded poles.

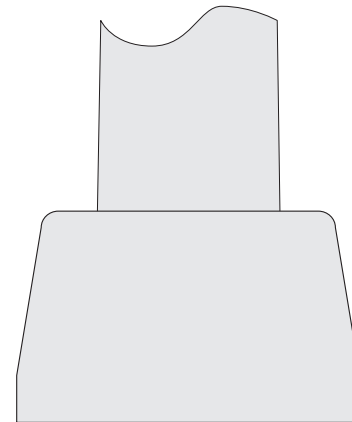

Whatley

A **valmont**  COMPANY



copyright 2006

Whatley Incorporated
6980 E. 54th Place
Commerce City, CO 80022
877 959-7678
www.whatley.com